

# M1

## FLEXFLO® Peristaltic Metering Pump



### Features

- > Tube Failure Detection senses tube rupture. No false triggering.
- > Heavy duty display shield protects pump controls.
- > Remote Start/Stop, which is one non-powered dry contact closure.
- > Compatible with Blue-White's Flow Verification Sensor.
- > Relay outputs include a single 250V/3A and a single solid state.
- > SCADA Inputs include: 4-20mA.

Video link: 



**NEMA 4X**

### Highlights

**Flow Range**

.0001 – 5.60 GPH  
.0004 – 21.2 LPH

**Pressures**

100 PSI  
(6.89 bar)

**Turndown ratio**

10,000 : 1

**Exclusive**

Enhanced Tube Failure Detection (TFD+)

**Motor**

Brushless  
DC

**Warranty**

5 Years

### Control Methods

Control Methods	Manual Control	4-20mA Input	Remote Start/Stop	Alarm Output	FVS	Motor Status Output
M1	•	•	•	•	•	•

<b>Maximum Working Pressure (Excluding pump tubes)</b>	100 PSI (6.89 bar)
<b>Maximum Fluid Temperature</b>	185 °F (85 °C)
<b>Maximum Viscosity</b>	5,000 centipoise
<b>Maximum Suction Lift</b>	30 ft. of water at sea level (14.7 atm psi)
<b>Ambient Operating Temperature</b>	14 °F to 115 °F (-10 °C to 46 °C)
<b>Ambient Storage Temperature</b>	-40 °F to 158 °F (-40 °C to 70 °C)
<b>Operating Voltage</b>	115V60Hz 1 PH (0.6A max.)
	220V50Hz 1 PH (0.3A max.)
	230V60Hz 1 PH (0.3A max.)
	230V50Hz 1 PH (0.3A max.)
	240V50Hz 1 PH (0.3A max.)
<b>Power Cord Options</b>	115V60Hz = NEMA 5/15 (USA)
	230V60Hz = NEMA 6/15 (USA)
	220V50Hz = CEE 7/VII (EU)
	240V50Hz = AS 3112 (Australia/New Zealand)
	230V50Hz = BS 1363/A (UK)
<b>Motor</b>	Brushless DC, 50W.
<b>Duty Cycle</b>	Continuous
<b>Motor Speed Adjustment Range</b>	10,000:1 (0.01% - 100%) Max rpm = 65rpm
<b>Maximum Overall Dimensions</b>	7.25" W x 9" H x 10" D (18.5 W x 22.9 H x 25.2 D cm)
<b>Product Weight</b>	6 lb. (2.7 Kg)
<b>Approximate Shipping Weight</b>	13 lb. (5.9 Kg)
<b>Approximate Shipping Dimensions</b>	10.5" W x 13.75" H x 11" D (26.7 W x 35 H x 28 D cm)
<b>Enclosure</b>	NEMA 4X (IP66), Valox® (PBT) Thermoplastic & PA12
<b>RoHS Compliant</b>	Yes
<b>Standards</b>	NSF/ANSI 61, cETLus, CE

# Materials of Construction

M1

## Non-wetted Components:

<b>Enclosure:</b>	Valox® (PBT) & PA12 thermoplastic
<b>Pump Head:</b>	Valox® (PBT) thermoplastic
<b>Pump Head Cover:</b>	Polycarbonate Permanently lubricated sealed motor shaft support ball bearing.
<b>Cover Screws:</b>	Stainless steel, polypropylene cap
<b>Roller Assembly:</b>	Rotor: Valox® (PBT) Rollers: Nylon Roller Bearings: Bronze
<b>TFD+ System Sensor:</b>	Polysulfone (PES)
<b>Power Cord:</b>	3 Conductor, SJTW-A water-resistant
<b>Tube Installation Tool:</b>	GF Nylon
<b>Mounting Brackets and Hardware:</b>	316 Stainless steel screws, GF Nylon bracket

## Wetted Components:

<b>Pump Tube Assembly:</b>	Tubing : Flex-A-Prene®, Flex-A-Thane® or Flex-A-Chem® Adapter Fittings: PVDF
----------------------------	---

# Output Specifications

Tube Model	Feed Rate		Max Speed	Max Pressure	Max Temperature
	GPH	LPH	RPM	PSI (bar)	°F (°C)
A1-1*	.0001 - 1.09	.0004 - 4.13	65	65 (4.50)	130 (54)
A1-3*	.0005 - 5.60	.0021 - 21.2	65	50 (3.45)	130 (54)
A1-6*	.0001 - 1.35	.0005 - 5.14	65	100 (6.89)	185 (85)
A1-7*	.0004 - 4.17	.0015 - 15.8	65	50 (3.45)	185 (85)
A1-8*	.0003 - 3.09	.0011 - 11.7	65	50 (3.45)	130 (54)

**NOTE:** Data pertains to both “T” and “M” connection types.

# Dimensions

Dim	Inch	cm	Dim	Inch	cm
A	9.46"	24.02	D	7.18"	18.23
B	9.92"	25.19	E	1.5"	3.81
C	7.18"	18.23			

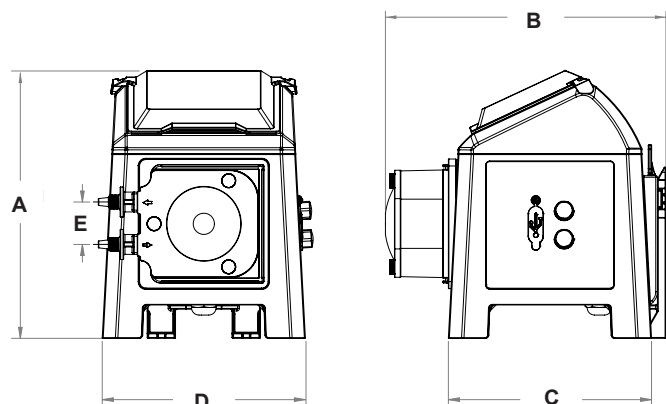

# Model Number Matrix

M1

## FLEXFLO® Model Number

<b>M1</b>	FLEXFLO® Peristaltic Metering Pump				
<b>Power Cord (Operating voltage requirement 96VAC to 264VAC)</b>					
<b>4</b>	115V 50/60Hz, power cord NEMA 5/15 plug (US)				
<b>5</b>	230V 50/60Hz, power cord NEMA 6/15 plug (US)				
<b>6</b>	220V 50/60Hz, power cord CEE 7/V11 plug (EU)				
<b>8</b>	240V 50/60Hz, power cord AS 3112 plug (Australia/New Zealand)				
<b>9</b>	230V 50/60Hz, power cord BS 1363/A plug (United Kingdom)				
<b>Pump Tube Size and Material</b>					
<b>1</b>	1/4" OD Flex-A-Thane®   0.0001-1.09 GPH   65 PSI				
<b>3</b>	7/16" OD Flex-A-Thane®   0.0005-5.60 GPH   50 PSI				
<b>6</b>	3/8" OD Flex-A-Prene®   0.0001-1.35 GPH   100 PSI				
<b>7</b>	7/16" OD Flex-A-Prene®   0.0004-4.17 GPH   50 PSI				
<b>8</b>	7/16" OD Flex-A-Chem®   0.0003-3.09 GPH   50 PSI				
<b>Inlet/Outlet Connection Size, Connection Type</b>					
<b>T</b>	3/8" OD x 1/4" ID Tube Compression Fitting				
<b>M</b>	1/2" Male NPT Fitting				
<b>MB</b>	1/2" Male BSPT Fitting, Natural PVDF (Kynar)				
<b>M1</b>	<b>4</b>	<b>-</b>	<b>1</b>	<b>T</b>	<b>Sample Model Number</b>

## Accessories



\*KIT-M12-3 THREE M12 CABLES

**NOTE:** Accessories sold separately.